



Manufacturer:
Kingfisher International Products Limited
3 Sheldon Square
London
W2 6PX
United Kingdom

EN

Distributor: **B&Q plc**
Chandlers Ford, Hants,
SO53 3LE United Kingdom
www.diy.com

SFD Limited
Trade House, Mead Avenue
Yeovil
BA22 8RT, UK



Petrol Lawnmower 167cc

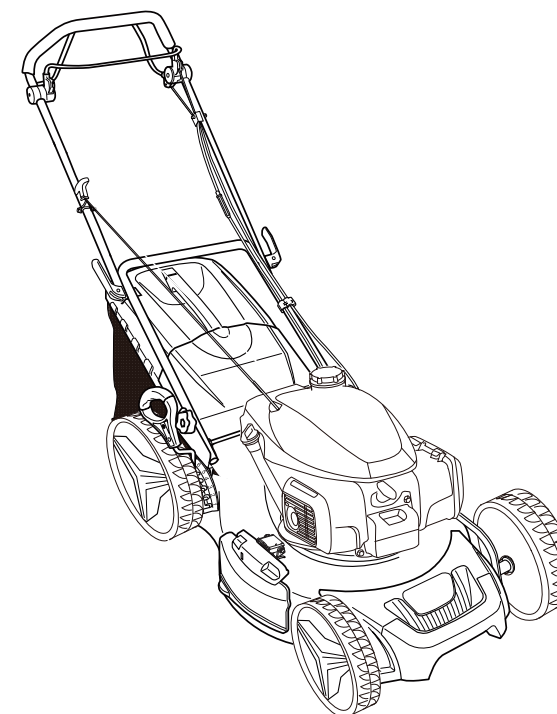

Original Instructions – MLMP170H51 GB_V01_20181119

MLMP170H51

EAN: 3663602423249

**WARNING: Read the instructions
before using the product**



EN

Let's get started...

These instructions are for your safety. Please read through them thoroughly before use and retain them for future reference.



Getting Started...

Safety information

Your product

Quick **start**

02

03

11

22



In more detail...

Product functions

Operation

Care and **maintenance**

Trouble shooting

Recycling and **disposal**

Guarantee

EC Declaration of conformity

24

25

30

35

39

41

41

42

Safety warnings

Petrol powered lawnmowers safety warnings



IMPORTANT: Read carefully before use
Keep for future reference



Training

1. Read the instructions carefully. Be familiar with the controls and the correct use of the product.
2. Never allow children or people unfamiliar with these instructions to use the product. Local regulations can restrict the age of the operator.
3. Never operate the product while people, especially children, or pets are nearby.
4. Keep in mind that the operator or user is responsible for accidents or hazards occurring to other people or their property.
5. The operators must receive proper training in the use, adjustment and operation of the product, including prohibited operations.

Preparation

1. While mowing, always wear substantial footwear and long trousers. Do not operate the product when barefoot or wearing open sandals.
2. Thoroughly inspect the area where the product is to be used and remove all objects which can be thrown by the product.
3. **WARNING** - Petrol is highly flammable.
 - Store fuel in containers specifically designed for this purpose.
 - Refuel outdoors only and do not smoke while refuelling.
 - Add fuel before starting the engine. Never remove the cap of the fuel tank or add petrol while the engine is running or when the engine is hot.
 - If petrol is spilled, do not attempt to start the engine but move the product away from the area of spillage and avoid creating any source of ignition until petrol vapours have dissipated.
 - Replace all fuel tank and container caps securely.

4. Replace faulty silencers.
5. Before using, always visually inspect to see that the cutting devices, cutting device bolts and cutter assembly are not worn or damaged. Replace worn or damaged cutting devices and bolts in sets to preserve balance.
6. On multi-bladed machines, take care as rotating one cutting device can cause other cutting devices to rotate.
7. **CAUTION!** Do not touch rotating cutting device.
8. Engine brake (brake bar (2)): Use the brake bar (2) to stop the engine. When you release the bar the engine and the blade stop automatically in a few second. To mow, hold the bar in the working position. Before you start to mow, check the brake bar (2) several times to be sure that it is working properly. Ensure that the brake wire (6) can be smoothly operated (i.e. is not catching or kinking in any way).

Operation

1. Do not operate the engine in a confined space where dangerous carbon monoxide fumes can collect.
2. Mow only in daylight or in good artificial light.
3. Do not operate the product while being tired, ill or under influence of alcohol or other drugs.
4. Avoid operating the product in wet grass, where feasible.
5. Always be sure of your footing on slopes.
6. Walk, never run.
7. Mow across the face of slopes, never up and down.
8. Exercise extreme caution when changing direction on slopes.
9. Do not mow excessively steep slopes near drop-offs, ditches or embankments.
10. Avoid using the product in bad weather conditions especially when there is a risk of lightning.
11. Use extreme caution when reversing or pulling the product towards you.
12. Stop the cutting device(s) if the product has to be tilted for transportation when crossing surfaces other than grass, and when transporting the product to and from the area to be mowed.
13. Never operate the product with defective guards, or without safety devices, for example deflectors and/or grass catchers, in place.
14. Do not change the engine governor settings or overspeed the engine.
15. Do not alter or tamper with any sealed adjustments for the engine speed control.
16. Do not tamper or disable any lawnmower safety systems or features.
17. Ensure and regularly check that all starting interlocks and operator presence controls are properly functioning.
18. Stop the product according to instructions in this manual before leaving the operator's position and park it.
19. Disengage all cutting device and drive clutches before starting the engine.
20. Start the engine or switch on the engine carefully according to instructions and with feet well away from the cutting device(s).

21. Do not tilt the product when starting the engine or switching on the engine, except if the product has to be tilted for starting. In this case, do not tilt it more than absolutely necessary and lift only the part which is away from the operator.
22. Do not start the engine when standing in front of the discharge chute.
23. Do not put hands or feet near or under rotating parts. Keep clear of the discharge opening at all times.
24. Never pick up or carry a product while the engine is running.
25. Stop the engine and disconnect the spark plug connector, make sure that all moving parts have come to a complete stop and, where a key is fitted remove the key:
 - before clearing blockages or unclogging chute,
 - before checking, cleaning or working on the product, after striking a foreign object. Inspect the product for damage • and make repairs before restarting and operating the product,
 - if the product starts to vibrate abnormally (check immediately).
26. Stop the engine and disconnect the spark plug connector, make sure that all moving parts have come to a complete stop and, where a key is fitted remove the key:
 - whenever you leave the product,
 - before refuelling.
27. Reduce the throttle setting during engine shut down and, if the engine is provided with a shut-off valve, turn the fuel off at the conclusion of mowing.
28. Never touch the exhaust, exhaust guard or cooling fins when the engine is hot.
29. Never carelessly touch the product, you can burn yourself. While the product is in operation or shortly thereafter, its parts such as the exhaust pipe, engine, and other surfaces are extremely hot! Pay attention to the markings on the product.
30. Make sure that the air intake of the combustion engine is clear. Keep the air intake free of dust, dirt particles, gases and fumes. Keep hands and feet away from the cutting device at all times and especially when switching on the engine.

Maintenance and storage

1. Follow the maintenance and repair instructions for this product. Never carry out any modifications of the product. Never change the preset rotary speed or the engine and product settings. Information about maintenance and repair is provided in this user manual.
2. Keep all nuts, bolts and screws tight to be sure the product is in safe working condition.
3. Improper maintenance or using non genuine parts may lead to malfunction/failure of the product. Many accidents are caused by poorly maintained products.
4. Never store the product with petrol in the tank inside a building where fumes can reach an open flame or spark.

5. Allow the engine to cool before storing in any enclosure.
6. Keep the engine, silencer and petrol storage area free of grass, leaves, or excessive grease to reduce the fire hazard.
7. Check the grass catcher frequently for wear or deterioration.
8. Replace worn or damaged parts for safety.
9. If the fuel tank has to be drained, this should be done outdoors.
10. Wear strong work gloves when removing and re-assembling the cutting device.
11. Always replace worn or faulty parts with the genuine parts. Only use the recommended blades and spare parts by the manufacturer.

Fuel handling

1. Always switch the product off and let it cool down, before refuelling it. Petrol is highly flammable. Never smoke when you are refuelling the product. Do not refuel the product, if there is an open fire in the vicinity!
2. Always use suitable aids such as funnels and filler necks. Do not spill any fuel on the product or its exhaust system. There is a risk of ignition. However, if fuel should be spilled, then you must remove it carefully from all parts of the product. Any residue which may be present must be completely removed, before the product is operated!
3. Exhaust gases and fuel fumes are noxious. Fuel fumes can ignite. Never use the product in environments where there is a risk of explosion.
4. Never breathe in any fuel fumes, when you are refuelling the product. Never fill the tank in enclosed spaces, such as basements or sheds. There is a risk of poisoning and explosion!
5. Avoid skin contact with petrol.
6. Do not eat or drink, while you are refuelling the product. If you have swallowed petrol or oil, or if petrol or oil has got into your eyes, then seek medical advice immediately.
7. Close the tank lid immediately after filling the tank. Make sure that it is properly closed.
8. Never use the product without an air filter.

Vibration and noise reduction

To reduce the impact of noise and vibration emission, limit the time of operation, use low-vibration and low-noise operating modes as well as wear personal protective equipment. Take the following points into account to minimize the vibration and noise exposure risks:

1. Only use the product as intended by its design and these instructions.
2. Ensure that the product is in good condition and well maintained.
3. Use correct attachment tools for the product and ensure they in good condition.
4. Keep tight grip on the handles/gripping surface.
5. Maintain this product in accordance with these instructions and keep it well lubricated (where appropriate).
6. Plan your work schedule to spread any high vibration tool use across a longer period of time.

Emergency

Familiarise yourself with the use of this product by means of this instruction manual. Memorise the safety directions and follow them to the letter. This will help to prevent risks and hazards.

1. **Always be alert when using this product, so that you can recognize and handle risks early.** Fast intervention can prevent serious injury and damage to property.
2. **Stop the engine and disconnect the spark plug connector if there are malfunctions.** Have the product checked by a qualified professional and repaired, if necessary, before you operate it again.
3. **In case of fire stop the engine and disconnect the spark plug connector.** Take fire-extinguishing measures immediately if the product switch is no longer accessible.



WARNING! Never use water to extinguish a product on fire. Burning fuel must be extinguished with special extinguishing agents! We recommend that you keep a suitable fire extinguisher within reach in your work area!

Residual risks

Even if you are operating this product in accordance with all the safety requirements, potential risks of injury and damage remain. The following dangers can arise in connection with the structure and design of this product:



1. Health defects resulting from vibration emission if the product is being used over long periods of time or not adequately managed and properly maintained.
2. Injuries and damage to property due to broken application tools or the sudden impact of hidden objects during use.
3. Danger of injury and property damage caused by flying objects.
4. Burns, if touching hot surfaces.



WARNING! This product produces an electromagnetic field during operation! This field may under some circumstances interfere with active or passive medical implants! To reduce the risk of serious or fatal injury, we recommend persons with medical implants to consult their doctor and the medical implant manufacturer before operating this product!

Symbols

On the product, the rating label and within these instructions you will find among others the following symbols and abbreviations. Familiarise yourself with them to reduce hazards like personal injuries and damage to property.

kW	Kilowatt	kg	Kilogram
cm ³	Cubic centimetre	dB(A)	Decibel (A-rated)
/min or min ⁻¹	Per minute	l	Litre
mm	Millimetre	m/s ²	Metres per second squared
	Lock / to tighten or secure.		Unlock / to loosen.

mm.yyyy Manufacturing date code, year of manufacturing (yyyy) and month of manufacturing (mm)



Note / Remark.



Caution / Warning.



Wear hearing protection.
Wear eye protection.



Wear respiratory protection.



Do not expose the product to rain or wet conditions.



Risk of fire / flammable materials



Open flames in the work area, around the product and in the vicinity of flammable materials are prohibited!



Read the instruction manual.



Wear protective gloves.



Wear protective, slip-resistant footwear.



Wear tight-fitted protective clothes.



Do not smoke in the work area, around the product and in the vicinity of flammable materials!



Hot surface, do not touch! High temperatures on the product's surfaces and structural parts that could cause burns, if they are touched. The product can also stay hot for a longer period of time after operation!



This product produces noxious exhaust fumes. If the product is used improperly, these fumes can lead to poisoning, a loss of consciousness or death!



Noxious exhaust fumes; do not operate or start the product in indoor rooms!



Only refuel unleaded petrol!



Add engine oil



Check and refill oil.



Switch the engine off while you are refilling the tanks!
Fuel is flammable, keep fire away. Do not add fuel with running engine.

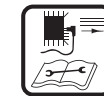

Switch the product off and disconnect the spark plug connector before assembly, cleaning, adjustments, maintenance, storage and transportation.



Mow across the face of slopes, never up and down.



Inspect the area where the product is to be used and remove all objects which can be thrown by the product.
If objects are hidden while operating stop the engine and remove the object.



Keep hands and feet away from sharp rotating parts – danger of injury!
When cleaning, repairing, or inspecting, make certain the cutting device and all mowing parts have stopped. Disconnect the spark plug cap, and keep the cap away from the plug to prevent accidental starting.



Keep hands and feet away



STOP

Cutting device continues to rotate after the product is switched off. Wait until all machine components have completely stopped before touching the product.



Pay special attention when working on the cutting device!



Objects thrown by the product could hit the user or other bystanders. Always ensure that other people and pets remain at a safe distance from the product when it is in operation. In general, children must not come near the area where the product is.

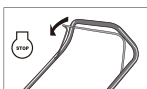

Release the brake bar to stop the engine and blade.



Pull the drive bar to engage the wheels.



Prevent engine malfunction by checking the engine oil level regularly.



Engine manual start; Recoil starter



Guaranteed sound power level value in dB

MLMP170H51

Designation of the tool (**M**: Macallister Brand; **LM**: Lawn mower; **P**: Petrol Power)



The product complies with the applicable European directives and an evaluation method of conformity for these directives was done.

Your product

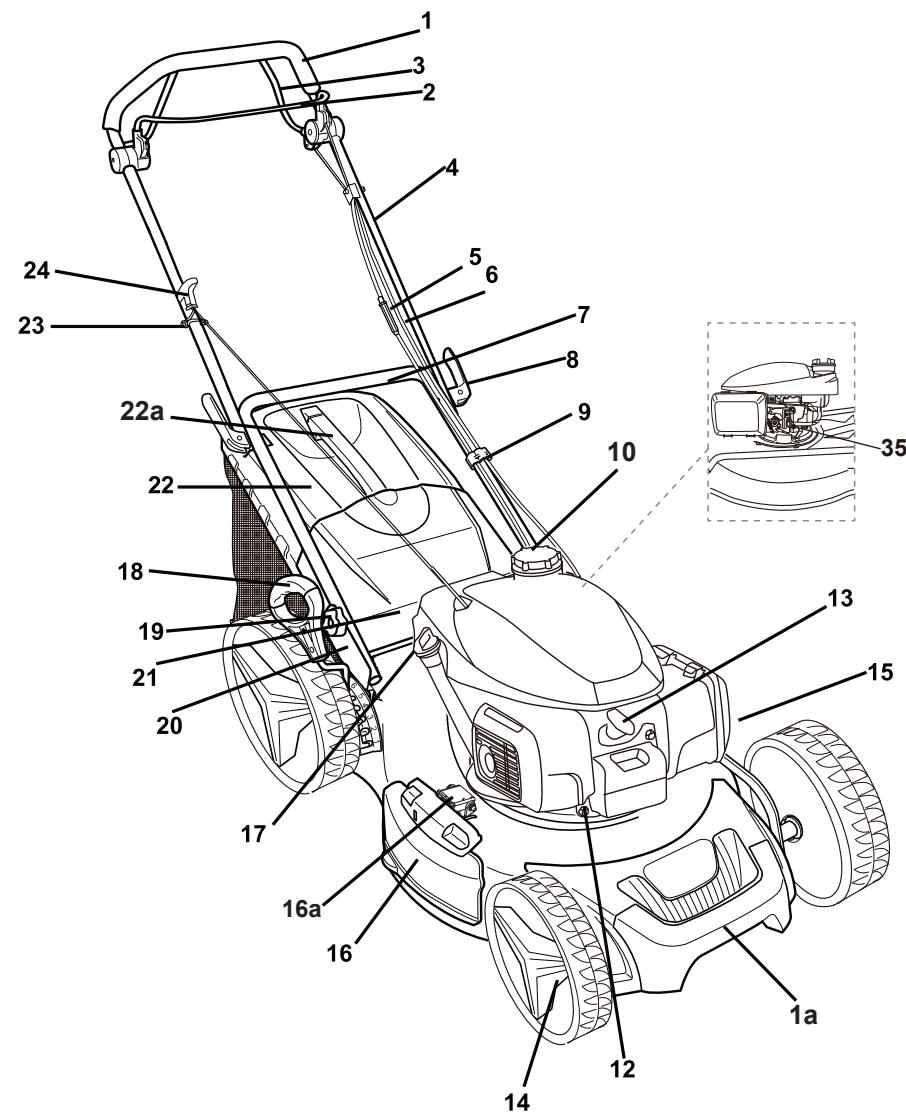

Your product

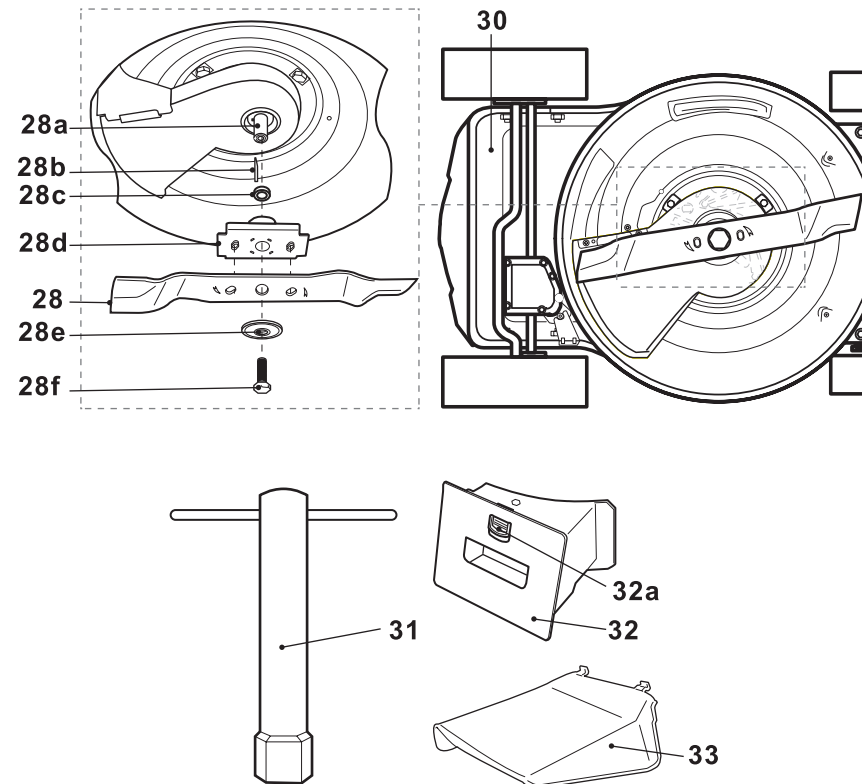

1. Handle
 - a. Transportation handle
2. Brake bar
3. Drive bar
4. Upper handle bar
5. Drive wire
6. Brake wire
7. Lower handle bar
8. Fixation lever (x 2)
 - a. Lever
 - b. Inner washer
9. Wire clip (x 1)
10. fuel tank cap
12. Muffler
13. Spark plug connector
14. Wheel
15. Air filter case
16. Side deflector guard
 - a. Lock buckle
17. oil tank cap
18. Lever for cutting height adjustment
19. Mounting set (x 4)
 - a. Bolt
 - b. Washer
 - c. Knob
20. Handle support
21. Rear deflector guard
22. Grass catcher
 - a. Handle
 - b. Hatch
23. Rope guide
24. Recoil starter handle
28. Cutting device (blade)
 - a. Spindle
 - b. Pin
 - c. Ring
 - d. Support
 - e. Locking flange
 - f. Hex bolt
30. Rear discharge chute
31. Spark plug wrench
32. Mulching insert
 - a. Unlock button
33. Side discharge attachment
34. Honda operator's manual *
35. Fuel valve lever



NOTE: Parts marked with * are not shown in this overview. Please refer to the respective section in the instruction manual.

Technical specifications

General

- > **Dimensions** approx. 1560 x 550 x 1080 mm
- > **Machine mass with empty tanks and In normal operating configuration:** approx. 33.3 kg
- > **Fuel tank capacity:** 910 ml (cm³)
- > **Petrol type:** #95, unleaded
- > **Engine oil capacity:** 400 ml (cm³)
- > **Engine oil type:** 4-stroke engine oil (e.g. SAE10W-30)
- > **Specific fuel consumption at max. engine power:** 313 g/kWh
- > **Fuel consumption at max. engine power:** 1.42 l/h
- > **Cutting width:** 51 cm
- > **Cutting height:** 25 - 75 mm; 7 levels
- > **Grass catcher volume:** 60 l

Engine

- > **Engine model:** HONDA GCV170
- > **Engine type:** 4-stroke, single cylinder, air cooled
- > **Engine displacement:** 167 cm³
- > **Maximum operating engine speed (rotational frequency):** 2800 min⁻¹
- > **Nominal power:** 3.1 kW
- > **Spark plug gap:** 0.7 - 0.8 mm

Sound level

- > **Sound pressure level at operator's position L_{pA} :** 84.4 dB(A)
- > **Uncertainty K:** 3 dB(A)
- > **Sound power level L_{WA} :** 93.6 dB(A)
- > **Uncertainty K:** 1.84 dB(A)
- > **Guaranteed sound power level L_{WA} (acc. to 2000/14/EC, amended by 2005/88/EC):** 98 dB(A)

Vibration level

- > **Hand arm vibration $a_{h,w}$:** 13.49 m/s²
- > **Uncertainty K:** 1.5 m/s²

The sound values have been determined according to noise test code given in EN ISO 5395-2, using the basic standards ISO 3744 and ISO 11094.

Wear hearing protection, especially when sound pressure is over 80 dB(A).

The declared vibration value has been measured in accordance with a standard test method (according to EN ISO 5395-1 and EN ISO 5395-2) and may be used for comparing one product with another. The declared vibration value may also be used to evaluate the exposure for the user caused by vibration in advance.



WARNING! Depending on the actual use of the product the vibration values can differ from the declared total! Adopt proper measures to protect yourself against vibration exposures. Take the whole work process including times the product is running under no load or switched off into consideration.

Proper measures include among others regular maintenance and care of the product and application tools, keeping hands warm, periodical breaks and proper planning of work processes.

Unpacking



NOTE: The product is heavy, ask another person for assistance if required.

1. Unpack all parts and lay them on a flat, stable surface.
2. Remove all packing materials and shipping devices if applicable.
3. Make sure the delivery contents are complete and free of any damage. If you find that parts are missing or show damage do not use the product but contact your dealer. Using an incomplete or damaged product represents a hazard to people and property.
4. Ensure that you have all the accessories and tools needed for assembly and operation. This also includes suitable personal protective equipment.



WARNING! The product and the packaging are not children's toys! Children must not play with plastic bags, sheets and small parts! There is a danger of choking and suffocation!

You will need

(items not supplied)

- > Suitable personal protective equipment
- > Fuel funnel with filter
- > Petrol and engine oil
- > Fuel collecting container
- > Oil collecting container
- > Lubrication oil/grease

(items supplied)

- > 1 x Spark plug wrench (31)
- > 1 x HONDA operator's manual (34)

Assembly



WARNING! The product must be fully assembled before operation! Do not use a product that is only partly assembled or assembled with damaged parts!



Follow the assembly instructions step-by-step and use the pictures provided as a visual guide to easily assemble the product!

Disconnect the spark plug connector (13) from the spark plug! Reconnect it after assembly.



NOTE: Take care of small parts that are removed during assembly or when making adjustments. Keep them secure to avoid loss.

Handle bars

1. Remove the mounting sets (19) from the handle support (20) and keep them handy.
2. Ensure that the levers (8a) are released and unfold the upper (4) and lower handle bar (7) (Fig. 1).

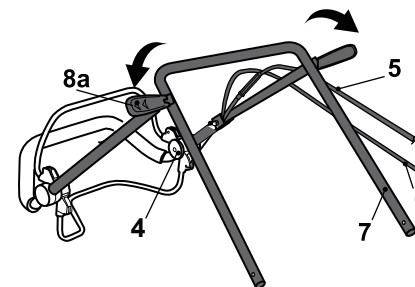

Fig. 1

3. Make sure the wires (5, 6) run on the upper side of the handle bars (4, 7).
4. Align the lower handle bar (7) with the handle support (20). Make sure the holes in the lower handle bar are aligned with those in the support (Fig. 2).

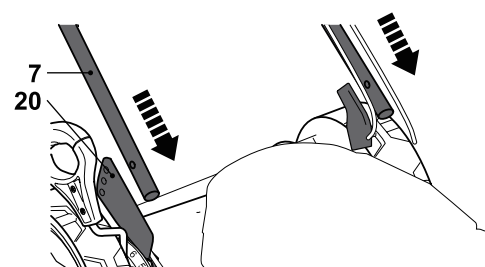

Fig. 2

5. Fix the lower handle bar (7) with the mounting sets (19) to the handle support (20) (Fig. 3).

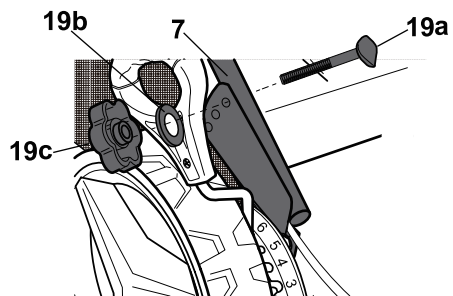

Fig. 3

6. Unfold the upper handle bar (4).
7. Lock the fixation levers (8a) to secure it (Fig. 4).

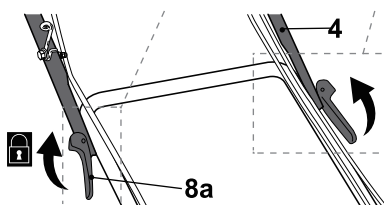

Fig. 4

8. Secure the wires (5, 6) with the wire clips (9) to the lower handle bar (7) (Fig. 5).

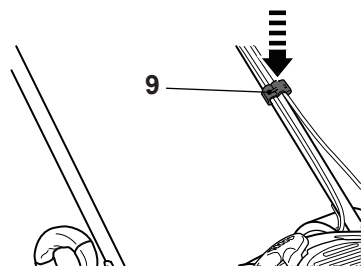

Fig. 5

Grass catcher

Open the rear deflector guard (21) hold it in position and align the hooks on the grass catcher (22) with the rod to hang it onto it (Fig. 6).

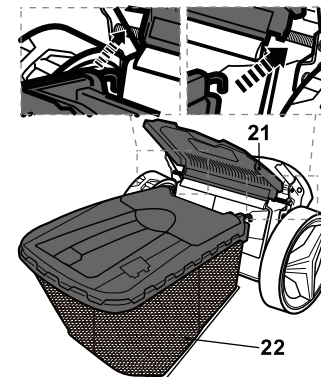

Fig. 6

Fuel and engine oil

This product is equipped with a 4-stroke engine. Before operation it is necessary to add proper fuel and engine oil separately.



WARNING! This product contains an instruction manual of the engine. Service the engine with proper petrol and engine oil as the instructed in the separate engine handbook (34).



It is important to read and understand these instructions of the engine and the equipment.

SAVE THESE ORIGINAL INSTRUCTIONS FOR FUTURE REFERENCE.

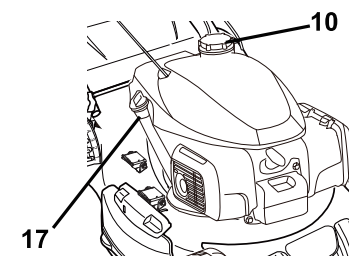

Fig. 7

1. Place the product on a stable, level surface. We recommend laying a non-flammable sheet under the product.
2. Use proper funnels. Avoid spilling and overfilling the tanks.



WARNING! Fuel and oil are highly inflammable! Fumes will explode if lit! Ensure that there are no naked flames around the product! Do not smoke while filling fuel and oil!

3. Always dispose of fuel, used oil and objects contaminated with them in accordance with local regulations.

Fuel



NOTE: This product is not supplied with fuel! Before operating this product it is essential to fill it with fuel! Fill fuel and engine oil separately. Never mix oil with petrol!



1. Always use clean, fresh unleaded petrol. Purchase fuel in quantities that can be used within 30 days.
2. Avoid getting dirt, dust or water in the fuel tank.
3. Unscrew and remove the fuel tank cap (10).
4. Add correct fuel into the tank. Leave a minimum 5 mm of space between the top of the fuel and the inside edge of the tank to allow for expansion (Fig. 8).

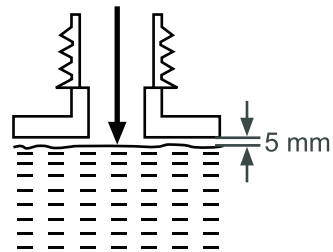

Fig. 8



NOTE: Petrol deteriorates over time. It may be difficult to start the engine if you use petrol which has been kept for more than 30 days.

Towards the end of the season, it is advisable to put only as much fuel in the tank as you need for each use, since it should be completely used up before storing the product.

Always empty the fuel tank when storing the product for over 30 days.

5. Wipe any spilled fuel with a soft cloth and reattach the fuel tank cap (10).

Engine oil



WARNING! This product is not supplied with oil. However, for manufacturing reasons it is possible that a small quantity may be in the engine! Before operating this product it is essential to fill it with proper oil (see the separate engine handbook (34)!

1. Unscrew and remove the oil tank cap (17).
2. Gradually add good-quality engine oil. Allow the oil to settle.
3. Check the oil level frequently while filling. Wipe the oil dipstick clean; refit and tighten the filler cap and then remove it again. The oil level must be between the “min” and “max” marking, indicated by the two arrows. Add more oil if necessary. Do not overfill (Fig. 9).

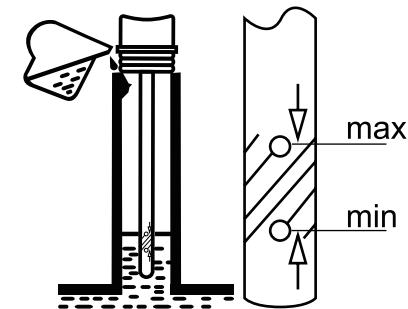
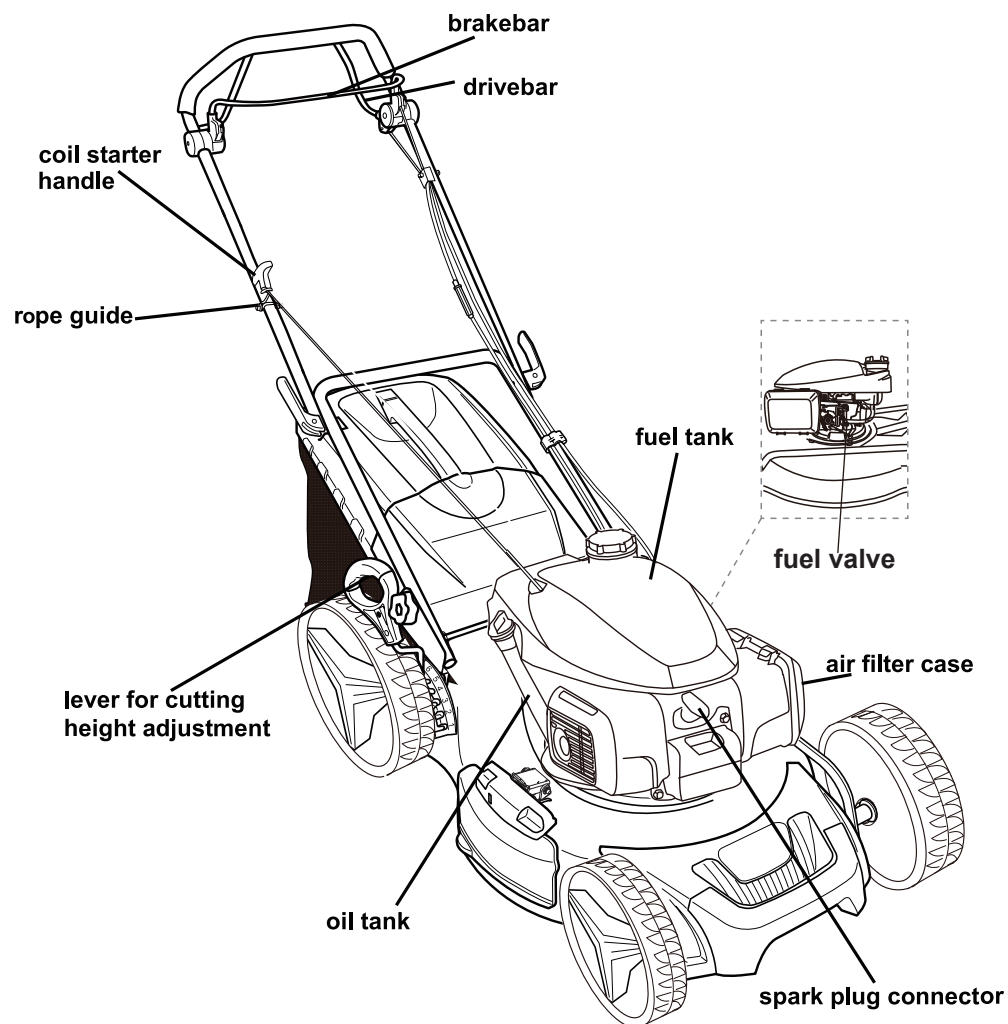

Fig. 9

4. Wipe spilled oil with a soft cloth and reattach the oil tank cap (17).

Operating controls



Set up



Assemble



Adjust



Add fuel



Add oil

Start

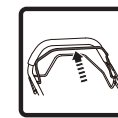
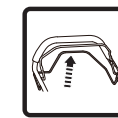

Open fuel valve

Pull and hold
brake leverPull recoil starter
sharply, repeat
until it startsPull and hold
drive bar

Operate

Stopping

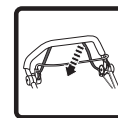

Release drive lever

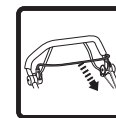

Release brake lever



Close fuel valve



Empty fuel tank



Clean and maintain



Store

In more detail...



Intended use

This petrol lawnmower MLMP170H51 is designated with a power output of 3.1 kW.

1. The product is intended for mowing grass in domestic gardens only. It must not be used to mow unusually high, dry or wet grass, e.g. pasture grass; for shredding leaves or mulching.
2. For safety reasons it is essential to read the entire instruction manual before first operation and to observe all the instructions therein.
3. This product is intended for private domestic use only, not for any commercial trade use. It must not be used for any purposes other than those described.

Handle adjustment

Adjust the handle to a suitable height according to your needs .

1. Release the mounting set (19), move the lower handle bar (7) to the desired position and fix it with the mounting set (Fig. 10, 11).
2. Release the fixation lever (8) and fold the handle assembly for storage. Ensure that the wires (5, 6) are not trapped (Fig. 12).

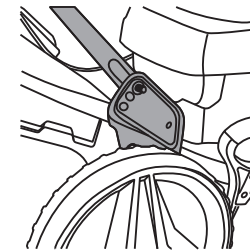

Fig. 10,
highest position

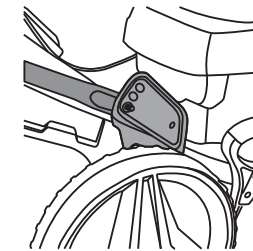

Fig. 11,
lowest position

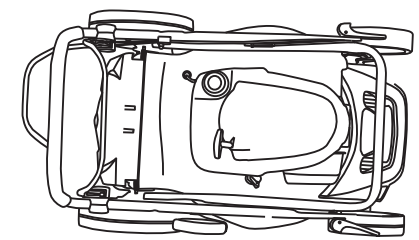

Fig. 12,
folded position

Product functions	25
Operation	30
Care and maintenance	35
Trouble shooting	39
Recycling and disposal	41
Guarantee	41
EC declaration of conformity	42



Recoil starter

The recoil starter handle (24) is positioned at the rear of the engine.

1. Pull the brake bar (2) towards the handle (1).
2. Slowly pull on the recoil starter handle (24) and fit it into the rope guide (23) on the right hand side of the upper handle (4) during operation. Do not remove the rope from the rope guide when starting the engine (Fig. 13).

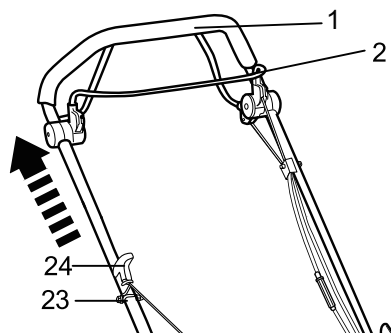

Fig. 13



WARNING! Never twist the starter cord around your hand! Only pull on the handle!



WARNING! Do not suddenly release the recoil starter handle! Allow the rope to return slowly and in a controlled manner each time it is pulled!

Grass catcher

Indicator

The grass catcher is equipped with a hatch (22b) that indicates the filling volume during operation.

1. When the hatch (22b) is opened the grass catcher (22) has enough volume left to collect grass (Fig. A).
2. When the hatch (22b) is closed the grass catcher (22) is full and must be emptied (Fig. B).

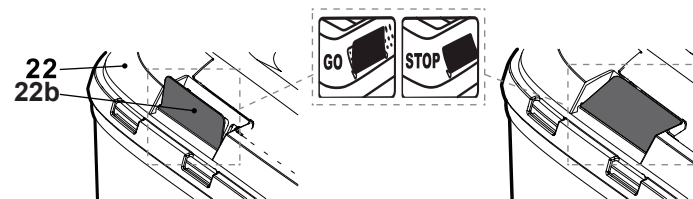

Fig. A

Fig. B

Emptying

Empty the grass catcher (22) frequently during use. Do not wait until it is completely full.



NOTE: A full grass catcher will reduce the performance of this product.

1. Lift the rear deflector guard (21) and pull the grass catcher (22) off the rod.
2. Remove the grass clippings from the rear discharge chute (30) into the grass catcher (22). Use a proper tool such as a brush.



WARNING! Never use your hands or feet to remove grass clippings from the discharge chute!



3. Remove the grass catcher (22).
4. Empty the grass clippings onto a compost heap.
5. Re-fit the grass catcher (22) to the product.



WARNING! Do not attempt to use the product without the grass catcher attached when collecting grass – **danger of flying objects!**

Switch the engine off and wait that the blade had come to a complete stop before removing the grass catcher!

Mulching insert

For mulching work use the mulching insert (32).

1. Open the rear deflector guard (21), hold it in position and insert the mulching insert (32) into the rear discharge chute (30). Ensure the unlock button snaps (32a) in place.

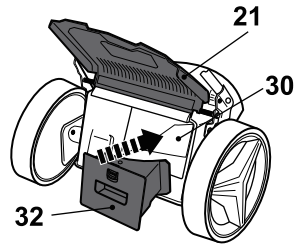

Fig. 14

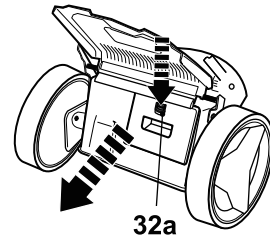

Fig. 15

2. Press the unlock button (32a) down to release and remove the mulching insert (32).

Side discharge attachment

1. Lift and hold the locking buckle (16a) upwards to unlock it.
2. Open the side deflector guard (16) and hold it in the open position. Hang the side discharge attachment (33) on the rods.

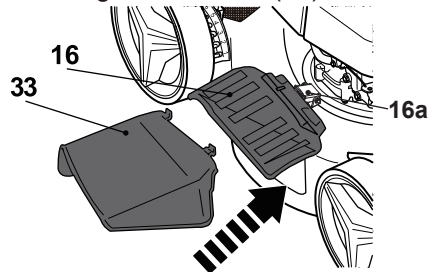

Fig. 16

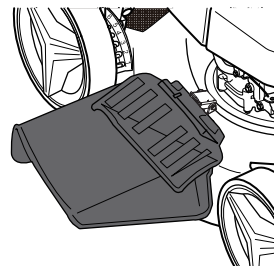

Fig. 17

Cutting height adjustment

Adjust the cutting height according to the needs of your lawn. The cutting height depends on the kind of lawn and its actual height. When mowing high grass, start with the maximum cutting height and make a second cut with lower cutting height.

1. Pull the lever (18) towards the wheel (14), then move it forward or backward to adjust the cutting height.

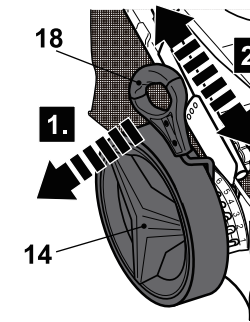

Fig. 18



WARNING! Ensure that the lever engages between two of the prongs! Switch the engine off and wait that the blade had come to a complete stop before adjusting the cutting height!

Brake bar

1. Pull the brake bar (2) towards the handle (1) and hold it in position when starting the engine. Keep it squeezed during operation.
2. Release the brake bar (2) to stop the engine.

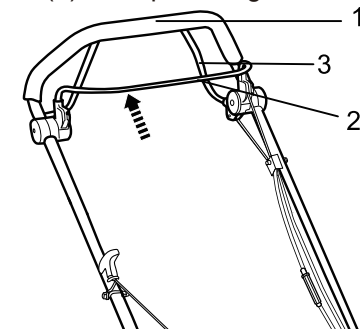

Fig. 19

Drive bar (self-propelled function)

Use the self-propelled function as assistance during operation; the rear wheels are automatically driven by the engine; you do not need to push the product manually (Fig. 19).

1. Pull the drive bar (3) towards the handle (1) to engage the wheels.
2. Release the drive bar (3) to disengage the wheels.

General operation

1. Check the product as well as accessories for damage before each use. Do not use the product if it is damaged or shows wear.
2. Double check that the accessories and attachments are properly fixed.
3. Check the fuel and oil level, refill if necessary.
4. Always push the product on its handle. Use the self-propelling function if required. Keep the handle dry and free from lubricant to ensure safe support.
5. Ensure that the air vents are always unobstructed and clear. Clean them if necessary with a soft brush. Blocked air vents may lead to overheating and damage the product.
6. Switch the product off immediately if you are disturbed while working by other people entering the working area. Always let the product come to complete stop before averting.
7. Do not overwork yourself. Take regular breaks to ensure you can concentrate on the work and have full control over the product.

Starting/Stopping



WARNING! Before starting, put the product on a flat surface free of high grass!
Clean the underside of the deck!

Keep yourself ready! The product will start moving forward once you hold the drive bar (3) towards the handle!

Start the engine carefully according to instructions. Keep your feet well away from the blade!

Do not tilt the product when starting the engine.

Start

1. Stand behind the handle (1).
2. Move the fuel valve lever (35) to position for the engine to run. When the engine is not in use, move the fuel valve lever (35) to the other side position (for preventing carburettor flooding and to reduce the possibility of fuel leakage).

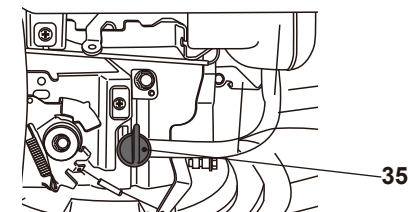

3. Pull the brake bar (2) against the handle (1), hold it in position with one hand (Fig. 20, 1.).
4. Pull the recoil starter handle (24) lightly until you feel resistance then pull it rapidly. Do it again until the engine starts (Fig. 20, 2.).
5. When you are ready to mow, hold the brake bar (2) with both hands, and pull the drive bar (3) towards the handle (1) (Fig. 20, 3.). The product starts moving forward and begins mowing.

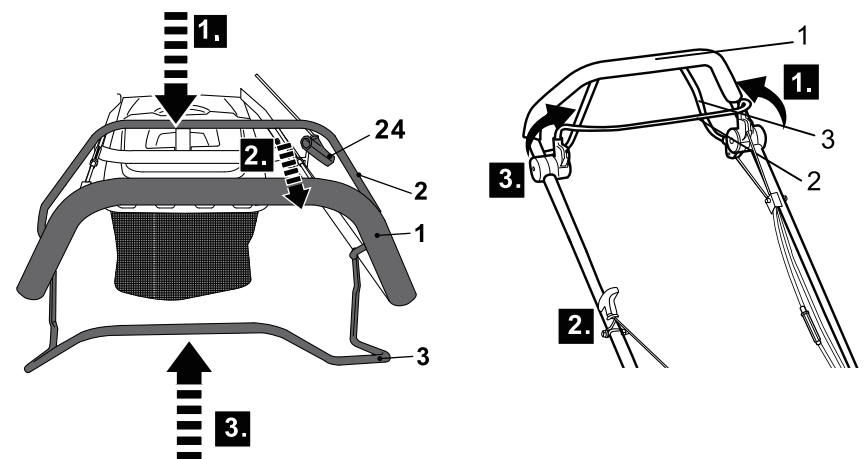

Fig. 20



NOTE: If the engine does not start, the engine may be flooded. Flooding is caused by too much fuel mixture applied at the wrong time and can prevent a product from starting. Follow below procedure:

Remove the spark plug (see the separate engine handbook). Dry the spark plug. Pull the recoil starter handle (24) for several times to drain the fuel from the combustion chamber.

Wait until fuel vapours and refit the spark plug. Clean up any spilled fuel and move the product at least 3 metres (10') away before starting the engine to avoid any accidental fire. Wait the engine to cool down then start the product as described in section "Start".



WARNING! The starting position should be as described in the instruction handbook. (Fig A) is the defined starting position. User should start the engine behind the lever. DO NOT start the engine standing beside the deck as (Fig B).



Fig. A



Fig. B

Stopping

1. Release the drive bar (3) to stop the self-propelled function (Fig. 21, 1.).
2. Release the brake bar (2) to stop the engine and blade (Fig. 21, 2.).

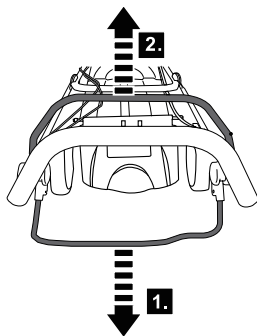

Fig. 21

Mowing

1. Make sure that the lawn is clear of stones, sticks, wire or other objects that could damage the product or its engine.
2. Do not cut wet grass because it tends to stick to the underbody of the product, preventing the proper discharge of grass clippings, and it could also cause you to slip and fall.

3. Never cut off more than one-third of the total length of the grass for a healthy lawn. In the autumn, lawns should only be cut as long as there is growth.
4. Slowly push the product forward.
5. Mow in slight overlapping rows. The most effective pattern for mowing lawns is straight lines along one of the sides. This will keep the rows even and ensures that all the lawn is cut without missing any spots (Fig. 22).
6. Circle around flower beds. When reaching a flower bed in the middle of the lawn, cut a row or two around the circumference of the bed.
7. Pay special attention when changing direction.
8. Empty the grass catcher regularly.

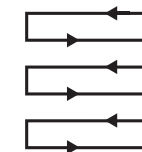

Fig. 22



WARNING! Extensive vibration of the product during operation is an indication of damage! Switch the engine off. The product should be promptly inspected and repaired!

9. Prepare the product according to required application.

Function	Grass catcher	Mulching insert	Side discharge attachment
Grass collection	attached	removed	removed
Mulching	removed	inserted	removed
Side discharge	removed	inserted	attached

Grass collection

1. Remove the mulching insert (32) and attach the grass catcher (22). Make sure the side discharge attachment (33) is not fitted to the product and the side deflector guard (16) is in place.
2. Empty the grass catcher regularly.

Mulching



NOTE: Mulching means cutting and returning the grass clippings to the lawn in one step: the grass clippings are cut very fine and then distributed evenly back onto the lawn. Under normal conditions, the mulched grass will biodegrade quickly to provide nutrients to the lawn.

1. Insert the mulching insert (32) into the rear discharge chute (30). Make sure the side discharge attachment (33) and grass catcher (22) are not fitted to the product and the side deflector guard (16) is in place.
2. Avoid mowing when the grass is wet from rain or dew. Wet grass may form clumps which interfere with the mulching action and reduce runtime. The best time to mow grass is late afternoon when the grass is dry and the newly cut area will not be exposed to direct sunlight.
3. Set the cutting height to about one third of the grass blade length, ideally no more than 35 mm at one time for best mulching performance. If the lawn is overgrown, it may be necessary to increase the cutting height to reduce the pushing effort and prevent the engine overloading. For extremely heavy mulching, it is advisable to first cut at a high cutting height, and then again to a lower cutting height. Otherwise, make narrower cuts and mow slowly.
4. Keep the housing free of built-up grass for best performance. From time to time switch the product off and wait for the blade to come to a complete stop. Then turn the product on its side. Using an object such as a wooden stick, remove any accumulation of grass in the blade area. Be careful of the sharp edges of the blade. Clean often after cutting new grass and after every use.
5. Certain types of grass or grass conditions may require an area to be mulched a second time to fully disperse the grass across the lawn. When cutting a second time, it is advisable to cut perpendicular (across) the first cutting pattern. Do not change the cutting pattern in any way that would cause you to mow downhill.
6. Change your cutting pattern from week to week. This will help prevent matting and graining of the lawn.

Side discharging



NOTE: When using the side discharge function, the grass clippings are discharged and spread across the ground.

Attach the side discharge attachment (33). Make sure the mulching insert (32) is inserted and the grass catcher (22) is not fitted to the product.

After use

1. Switch the product off, disconnect the spark plug connector and let it cool down.
2. Check, clean and store the product as described below.

The golden rules for care



WARNING! Always switch the product off, disconnect the spark plug connector and let the product cool down before performing inspection, maintenance and cleaning work! DO NOT touch a rotating blade.

1. Keep the product clean. Remove debris from it after each use and before storage.
2. Regular and proper cleaning will help ensure safe use and prolong the life of the product.
3. Inspect the product before each use for worn and damaged parts. Do not operate it if you find broken and worn parts.



WARNING! Only perform repairs and maintenance work according to these instructions! All further works must be performed by a qualified specialist!

General cleaning

1. Clean the product with a slightly damp cloth and mild soap. Use a brush for areas that are hard to reach.
2. In particular clean the air vents (11) after every use with a cloth and brush.
3. Remove stubborn dirt with high pressure air (max. 3 bar).



NOTE: Do not use chemical, alkaline, abrasive or other aggressive detergents or disinfectants to clean this product as they might be harmful to its surfaces.

4. Check for worn or damaged parts. Replace worn parts as necessary or contact an authorised service centre for repair before using the product again.

Maintenance

Before and after each use, check the product and accessories (such as application tools) for wear and damage. If required, exchange them for new ones as described in this instruction manual. Observe the technical requirements.

Underbody and cutting device



WARNING! Wear protective gloves when working on the cutting device and close to it! Use proper tools to remove debris, e. g. a wooden stick! Never use your bare hands!



Always use original spare parts for replacement. The cutting device must be replaced by an identification no. ref. DAYE 263001330. Do not attach any other type of cutting device!

The replacement of the cutting device should be done by an experienced user! Rework or sharpening blades is not recommended unless it is done by a repair service or a similarly qualified specialist!



NOTE: We strongly recommend jacking the product up when performing inspection and work on the cutting device. Avoid tilting the product in order to prevent fuel and oil leakages.

1. Keep the underbody and cutting device (28) clean and free of debris. Remove clippings from the rear discharge chute (30).
2. Check all nuts and bolts periodically for tightness before operation. After prolonged use, especially in sandy soil conditions, the cutting device will become worn and lose some of the original shape. The cutting efficiency will be reduced and the cutting device should be replaced.
3. Keep the cutting device (28) sharp to ensure a good cutting performance. Replace a worn or damaged cutting device with a new one of the same type or have it sharpened by a qualified specialist.
4. Loosen the hex bolt (28f) anti-clockwise using a suitable wrench and remove it together with the locking flange (28e), cutting device (28) (Fig. 23).
5. Replace the cutting device with a new one of the same type. Then refit locking flange (28e) and hex bolt (28f). Tighten the hex bolt clockwise with 40 N m min, 50 N m max. to ensure safe operation of your product.



NOTE: Replace this cutting device after 50 hours mowing or 2 years whichever is sooner regardless of condition. If the cutting device is cracked or damaged, you must immediately replace it with a new one.

6. Lubricate the cutting device (28) after each use to prolong the life span of cutting device and product. Apply light machine oil along the edge of the cutting device.

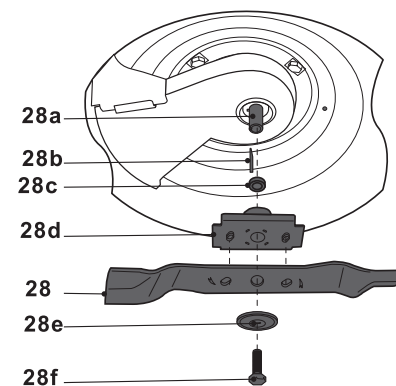

Fig. 23

Grass catcher

1. Inspect the grass catcher (22) before each use. Do not use it if you find any damage.
2. Clean the grass catcher (22) after operation using water and mild soap.
3. Let the grass catcher dry thoroughly before storing to avoid mildew.

Wires

Check the performance of the wires (5, 6) before each use. Ask a qualified specialist to adjust it if necessary.



WARNING! Do not use the product with defective or loose wires!

Engine



NOTE: An instruction manual of the engine is provided with your product. Follow the engine handbook for maintenance and care for of engine.

Refer to the HONDA operator's manual for maintaining below parts.

- | | | |
|--------------|---------------|--------------|
| > Air filter | > Engine oil | > Valve play |
| > Spark plug | > Carburettor | |
| > Fuel | > Muffler | |

Spare parts/Replacement parts

The following parts of this product may be replaced by the consumer. Spare parts are available at an authorised dealer or through our customer service.

Description	Model no. or Specification
Blade	Code: DAYE 263001330

Repair

This product does not contain any parts that can be repaired by the consumer. Contact an authorised service centre or a similarly qualified person to have it checked and repaired.

Storage

1. Switch the product off and disconnect the spark plug connector.
2. Clean the product as described above.
3. Store the product and its accessories in a dry, frost-free place.
4. Always store the product in a place that is inaccessible to children. The ideal storage temperature is between 10 °C and 30 °C.
5. We recommend using the original package for storage or covering the product with a suitable cloth or enclosure to protect it against dust.
6. Empty the tank if you are not going to use the product for an extended period of time (more than 30 days) and before storing it for the winter.

Transportation

1. Switch the product off and disconnect the spark plug connector.
2. Adjust the height to the highest position as described above.
3. Attach transportation guards, if applicable.
4. Always transport the product by its handles (1, 1a).
5. Protect the product from any heavy impact or strong vibrations which may occur during transportation in vehicles.
6. Secure the product to prevent it from slipping or falling over, loss of fuel, damage and injury.

Trouble shooting

Suspected malfunctions are often due to causes that the user can fix themselves. Therefore check the product using this section. In most cases the problem can be solved quickly.



WARNING! Only perform the steps described within these instructions! All further inspection, maintenance and repair work must be performed by an authorised service centre or a similarly qualified specialist if you cannot solve the problem yourself!

Problem	Possible cause	Solution
1. Engine does not start	1.1 Not enough fuel in fuel tank	1.1 Add fuel
	1.2 Spark plug is wet	1.2 Dry spark plug
	1.3 Spark plug is damaged	1.3 Replace spark plug
	1.4 Spark plug connector loose	1.4 Attach properly
	1.5 Choke control lever not in the correct position for the prevailing conditions	1.5 Move choke control lever to correct position
	1.6 Air filter is dirty	1.6 Clean air filter
	1.7 Spark plug loose	1.7 Tighten spark plug 25-30 N m
	1.8 Spark plug gap is incorrect	1.8 Set gap between electrodes at 0.7-0.8mm
	1.9 Carburettor is flooded with fuel	1.9 Remove air filter and pull recoil starter handle continuously until carburettor clears itself and install air filter
	1.10 Faulty ignition module	1.10 Contact the service agent
2. Engine stops	2.1 Not enough fuel in fuel tank	2.1 Add fuel
	2.2 Cutting device is blocked	2.2 Remove blockage
3. Engine difficult to start or loses power	3.1 Dirt, water or stale fuel in the tank	3.1 Drain fuel and clean tank. Fill tank with clean, fresh fuel
	3.2 Vent hole in fuel tank cap is clogged	3.2 Clean or replace fuel tank cap
	3.3 Air filter is dirty	3.3 Clean air filter

Problem	Possible cause	Solution
4. Engine operates erratically	4.1 Spark plug is defective	4.1 Install new, correctly gapped plug
	4.2 Spark plug gap is incorrect	4.2 Set gap between electrodes at 0.7-0.8 mm
	4.3 Air filter is dirty	4.3 Clean air filter
5. Engine idles poorly	5.1 Air filter is dirty	5.1 Clean air filter
	5.2 Air vents are clogged	5.2 Remove debris from vents
	5.3 Cylinder fins are blocked	5.3 Remove debris from cylinder fins
6. Engine skips at high speed	6.1 Gap between electrodes of spark plug is too close	6.1 Set gap between electrodes at 0.7-0.8 mm
7. Engine overheats	7.1 Air vents are clogged	7.1 Remove debris from vents
	7.2 Incorrect spark plug	7.2 Install correct spark plug and cylinder fins on engine
8. Unsatisfactory result	8.1 Cutting device dull	8.1 Replace with a new one
	8.2 Cutting material exceeds capacity	8.2 Only cut materials acc. to the capacity of the product.
	8.3 Cutting height is incorrect	8.3 Adjust cutting height
9. Excessive vibration/ noise or exhaust	9.1 Cutting device is dull/damaged	9.1 Replace with a new one
	9.2 Bolts/nuts are loosen	9.2 Tighten bolts/nuts
	9.3 Petrol/oil is incorrect	9.3 Empty out unused petrol/oil and refill with the correct petrol/oil

Recycling and disposal

1. Old products are potentially recyclable and do not, therefore, belong in your household rubbish. You are requested to assist us and our contribution to saving resources and protecting the environment by handing in this product at an equipped collection centre (if there is one available).
2. Petrol, oil, used oil, a mixture of oil and petrol and objects soiled with oil e. g. cleaning cloths do not belong in the household rubbish. Dispose of oil-contaminated items in accordance with the local guidelines and hand them in at recycling centres.
3. The product comes in a package that protects it against damage during shipping. Keep the package until you are sure that all parts have been delivered and the product is function properly. Recycle the package afterwards.

Guarantee

This product carries a guarantee of 24 months starting from the day of purchase. Please retain your receipt as a proof.

This guarantee specifically excludes losses due to:

- Normal wear and tear, including accessory wear
- Overload, misuse or neglect
- Failure of consumable items (such as batteries)
- Repairs attempted by anyone other than an authorized agent
- Accidental damage caused by foreign objects or substances
- Lack of routine maintenance
- Failure to follow manufacturer's guidelines
- Loss of use of the goods

Due to continuous product improvement, we reserve the right to change the product specification without prior notice.

This guarantee does not affect your statutory rights.

For any inquiries relating to the guarantee please contact your retailer : If you purchased this product in B&Q store or website then call 0333 0143101. If you bought this product in SFX outlet or website then call 03330 112 112.

For after sales
help and advice,
please call

sertronics
SERVICE FOR ELECTRONICS

HELPLINE
0800 4840045

Email: ServiceKF-UK@sertronics.de

EC declaration of conformity



We

Kingfisher International Products Limited
3 Sheldon Square
London W2 6PX
United Kingdom

Declare that the product

Petrol Lawnmower, 167 cm³, MLMP170H51

Serial number: from 0000000001 to 9999999999

Complies with the essential health and safety requirements of the following directives:

The Machinery Directive 2006/42/EC

EN ISO 5395-1:2013+A1:2018

EN ISO 5395-2:2013+A1:2016+A2:2017

The EMC Directive 2014/30/EU

EN ISO 14982:2009

The Outdoor Noise Directive 2000/14/EC & 2005/88/EC

Measured Sound Power Level: 93.6 dB(A)

Guaranteed Sound Power Level: 98 dB(A)

EN ISO 3744:1995; ISO 11094:1991

Certificate registration number: OR/005531/098

Test report No.: 704031801913

Conformity assessment procedures: Annex VI of the directive

Notified body: 0036, TÜV SÜD Industrie Service GmbH, Westendstraße 199, 80686
München Germany

**The Regulation of Non-Road Mobile Machinery Emissions (EU) 2016/1628, and its
supplemented regulations**

Engine model: Honda GCV170

Engine manufacturer: Honda Corporation

Authorised Signatory and technical file holder:

Name/Title: Lisa Davis/Group Quality Director

Date: 19.11.2018

Kingfisher International Products Limited
3 Sheldon Square London W2 6PX United Kingdom